

D16-MG

16 litre, in-line 6 cylinder - Constant engine speed

450 kWm at 1500 rpm & 500 kWm at 1800 rpm

IMO NOx Tier II and CCNR Stage 2



D16-MG is a reliable, powerful, fuel-efficient and clean marine diesel engine. It's based on Volvo Group's proven engine platform and is designed by Volvo Penta to power a wide range of marine auxiliary applications.

This 16 litre turbocharged diesel engine has a robust and dependable design with an overhead camshaft, four valves per cylinder and precisely controlled electronic fuel injection. It features Volvo Group's proven combustion technology which creates an optimized fuel to air pressure ratio at any work load. Together with Volvo Group's Engine Management System it offers powerful response, fuel efficiency and excellent emission performance. The robust cylinder block is fitted with a ladder frame for smooth operation and low noise.

Typical applications:

- Gensets
- Diesel Electric applications
- Pumps
- Cranes
- Hydraulic power packs
- Air compressors
- Fire-fighting equipment

The compact and space saving design makes for easy installation and easily accessible service points.

- Proven design - built on Volvo Group technology
- Fuel-efficient and low emission levels
- High load acceptance
- Low weight, noise and vibrations
- Type-approved
- Classifiable by all major societies
- Compact installation and easy to service

The engine can be equipped with a wide range of optional equipment and is available with Heat Exchanger (HE), Keel Cooled (KC) or Radiator Cooled (RC) cooling system. Two options for on-board electronic control: The type-approved MCC (Marine Commercial Control) or Open Can Interface. The engine and equipment can be covered with the Extended Coverage which prolongs the standard warranty up to five years - or the corresponding number of running hours.

D16-MG

Technical Data

General

Engine designation	D16-MG
Configuration	in-line 6
Method of operation	4-stroke, direct-injected, turbocharged diesel engine with charge air cooler
Bore/stroke, mm (in.)	144/165 (5.67/6.50)
Displacement, litre (in ³)	16.12 (983.9)
Compression ratio	17.5:1
Dry weight bobtail HE ¹⁾ , kg (lb)	1750 (3858)
Dry weight bobtail KC ²⁾ , kg (lb)	1624 (4242)
Dry weight bobtail RC ³⁾ , kg (lb)	1695 (3737)
Flywheel housing/SAE size	14"/SAE1

Performance, fuel & emissions

Engine speed	1500 rpm	1800 rpm	
Crankshaft power HE, kW	450	500	
Crankshaft power KC, kW	450	500	
Crankshaft power RC, kW ⁴⁾	433	470	
Spec.fuel.consump., g/kWh	at 50% load	208	212
	at 75% load	203	209
	at 100% load	206	213
Emission compliance	IMO NOx Tier II	IMO NOx Tier II	
	CCNR Stage 2	CCNR Stage 2	
Recommended fuel to conform to	ASTM-D975 1-D and 2-D, EN 590 or JIS KK 2204		

10% overload available acc. to class requirements. Fuel temperature 40°C (104°F). Technical data according to ISO 3046 Fuel Stop Power with a tolerance ±4%. Fuel with a lower calorific value of 42700 kJ/kg and density of 840 g/liter at 15°C (60°F). Merchant fuel may differ from this specification which will influence engine power output and fuel consumption.

¹⁾ Heat Exchanger cooled system (HE), ²⁾ Radiator Cooled system (RC), ³⁾ Keel Cooled system (KC)

⁴⁾ With fan.

D16-MG

Technical description

Engine and block

- Cylinder block and cylinder head made of cast iron
- One piece cylinder head
- Replaceable wet cylinder liners and valve seats/guides
- Drop forged crankshaft with induction hardened bearing surfaces and fillets with seven main bearings
- Four valve per cylinder layout with overhead camshaft
- Each cylinder features cross-flow inlet and exhaust ducts
- Gallery oil cooled forged aluminum pistons, three piston rings (keystone top ring)
- Senders for oil pressure (after filter), oil temp, oil pressure piston cooling, oil level, fuel pressure, freshwater pressure, exhaust temp, crankcase pressure, speed crank and cam, boost pressure/temp, seawater pressure (not KC or RC cool.), coolant level, coolant temp
- Open or closed crankcase ventilation

Lubrication system

- Freshwater-cooled oil cooler integrated in cylinder block
- Twin full flow oil filter of spin-on type and single by-pass filter

Fuel system

- Electronic Unit Injectors
- Gear-driven fuel pump, driven by timing gear
- Electronically controlled injection timing
- 5-hole high pressure injector nozzles

- Twin engine-mounted spin-on fine fuel filters with change over valve

Turbocharger

- Dry twin entry turbocharger

Heat Exchanger cooled system (HE)

- For seawater- and central-cooled engines
- Engine-mounted tubular heat exchanger with expansion tank
- Belt-driven centrifugal freshwater pump
- Gear-driven rubber impeller raw water pump (optional)

Keel Cooled system (KC)

- 2-circuit cooling system
- Belt-driven centrifugal cooling water pump in HT circuit
- Engine mounted expansion tank in HT circuit
- Gear driven rubber impeller cooling water pump in CAC LT circuit

Radiator Cooled system (RC)

- For aircooled engines
- V-belt-driven radiator fan
- Belt-driven centrifugal cooling water pump
- Water-cooled CAC (Charge Air Cooler)

Control System

- Two options available:
 1. MCC a flexible and expandable control and monitoring system for classified installations. Incl. separate safety shutdown systems.
 2. Open Can Interface, engine delivered

without control system. Different options with or without shut down senders and switches.

- Meets classification requirements of separate shutdown and monitoring system
- Easy to interface with leading suppliers of ship control systems
- Possibility to connect relays for remote control functions (potential free contacts)
- Classifiable by all major classification societies

Optional equipment

Engine

- Twin fuel pre-filters/water separator with change over valve
- Flexible exhaust compensator
- Cooling water connection bellows
- Electrical and air starting systems available individually or in parallel.
- Raw water pressure indication (only in combination with raw water pump)
- Exhaust temperature indication
- Engine heater 2000W
- Dry exhaust silencer with or without spark arrestor
- 110A alternator with integrated charging sensor (Only available for HE/KC)

Miscellaneous

- Basic toolkit
- Spare parts according to classification recommendations

Dimensions

Not for installation, mm (in.)

Engine with HE & KC

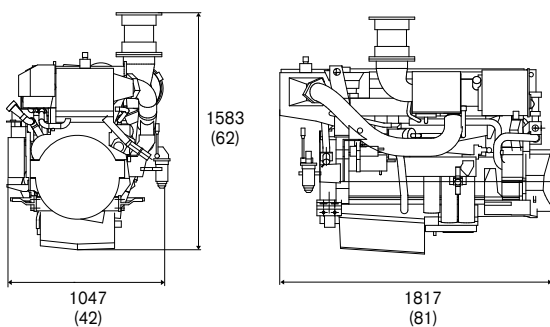

Engine with RC

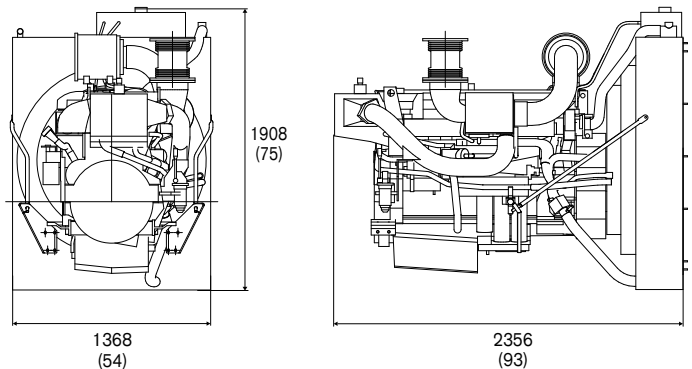

Volvo Penta is part of the Volvo Group, the world's leading manufacturer of trucks, buses, construction equipment and diesel engines. Volvo Penta has approximately 4,000 dealers in some 130 countries.

For further information, please contact your local Volvo Penta dealer or visit www.volvopenta.com.

Not all models, standard equipment and accessories are available in all countries. All specifications are subject to change without notice. The engine illustrated may not be entirely identical to production standard engines.

VOLVO PENTA

AB Volvo Penta
SE-405 08 Göteborg, Sweden
www.volvopenta.com